



Paul Cox

Group Managing Director,
Specialty Engineering

smiths
specialty engineering
bringing technology to life

Investor Day: Bringing technology to life, London, Thursday, 3 May 2007

Specialty Engineering profile

- Global revenues £1.1bn (2006)
Net margin of 14.3%
- Majority of revenue comes from sustainable growth markets
- Strong technologies & brands in markets served
- History of building on organic growth platforms and increasing margins
- Further acquisitive opportunities to accelerate achievement of strategic goals
- Net M&A proceeds c£0.8bn

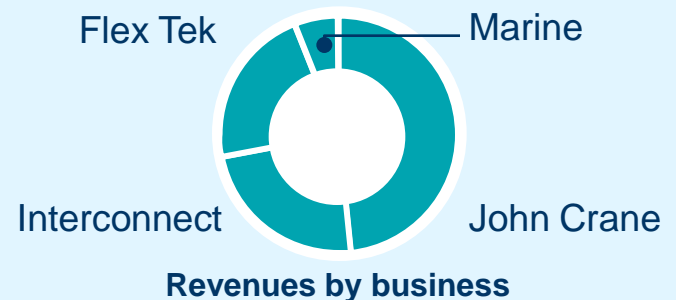
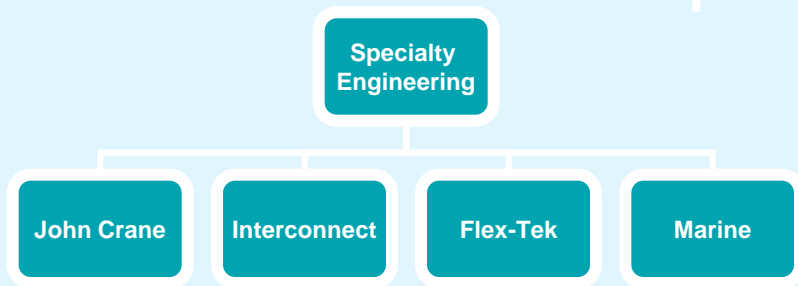
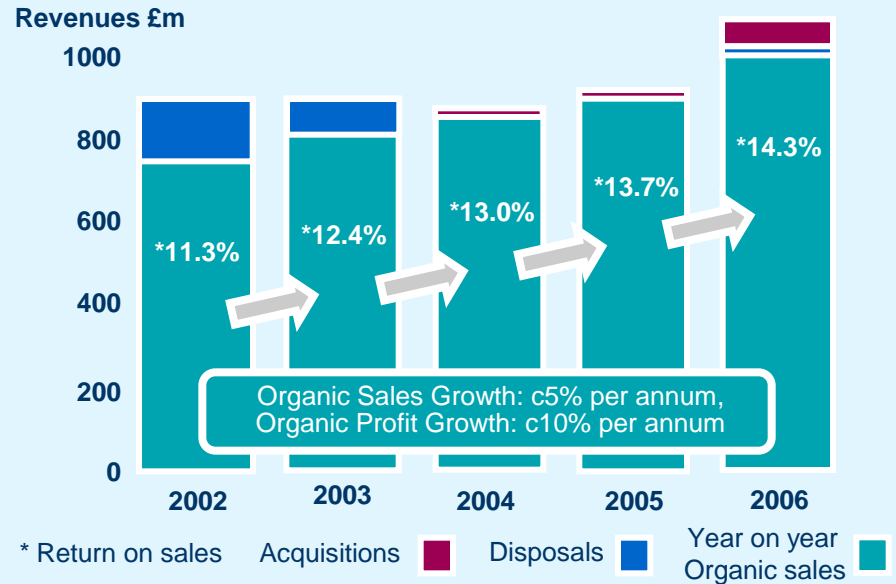

Focused on Profitable Growth

Specialty Engineering: How we do what we do

**Operating in sectors
of high growth**

Petrochemical, Mil/Aero and Wireless markets

**Reaching deep
into global markets**

Our global presence

**Developing
technology to help
customers succeed**

Technologies employed and examples

**Delivering constant
improvement**

Initiatives and opportunities

**Improving
the business mix**

Initiatives and opportunities

**Doing business
the right way**

A culture of ethical behaviour

Specialty Engineering markets

Operating in sectors of high growth

2006 Revenues by market (£1.1bn)

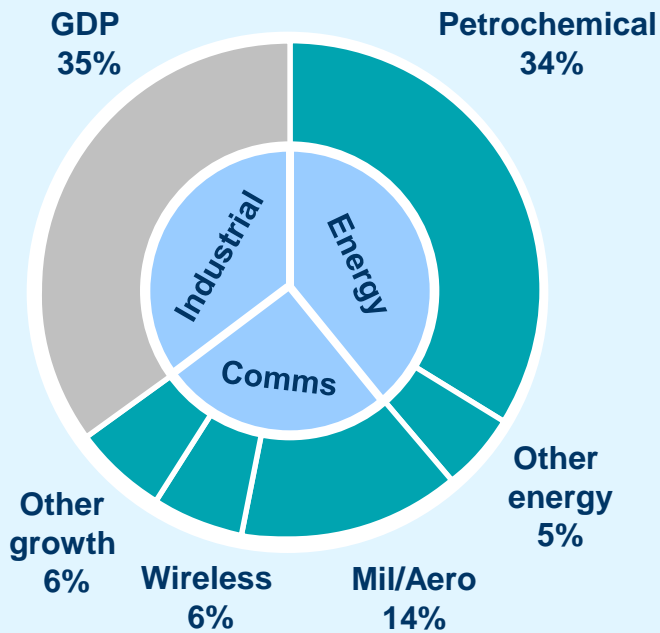

Markets	John Crane	Interconnect	Flex-Tek	Marine
Petrochemical				
Mil/Aero				
Wireless				
Other Energy				
Other Growth				
GDP Markets				

Key: ← % revenues in market

Roughly two thirds of revenues in growth markets

Specialty Engineering markets

Operating in sectors of high growth

2006 Revenues by market (£1.1bn)

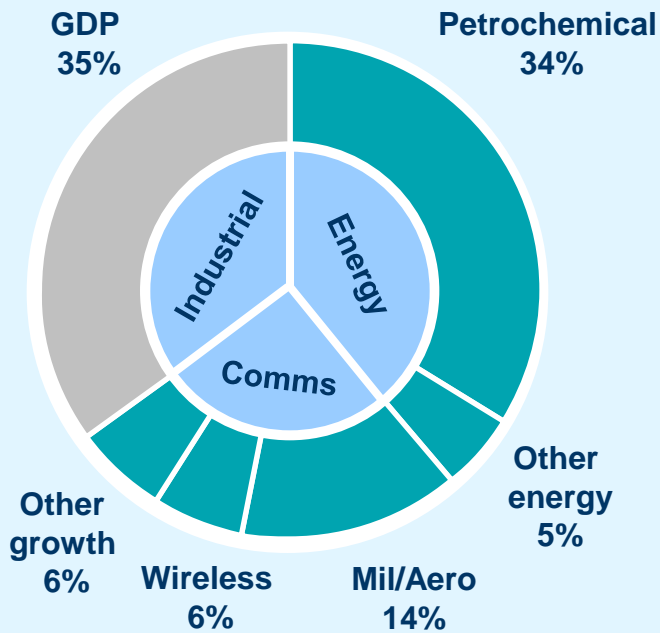

Markets	John Crane	Interconnect	Flex-Tek	Marine
Petrochemical				
Mil/Aero				
Wireless				
Other Energy				
Other Growth				
GDP Markets				

Key: ← % revenues in market

Roughly two thirds of revenues in growth markets

Petrochemical market drivers

Operating in sectors of high growth



Upstream

- Petrochemical extraction and initial processing
- Production stimulation (injection /produced water re-injection)



Midstream

- Crude/End Product Pipelines (liquids)
- Gas Pipelines (compression)
- Liquid Natural Gas (compression and shipping)



Downstream/Petrochemical/CPI/Power

- Oil Refining
- Gas Processing
- Petrochemicals/Intermediates
- Basic Chemicals
- Specialty Chemicals
- Power Generation



Global energy consumption

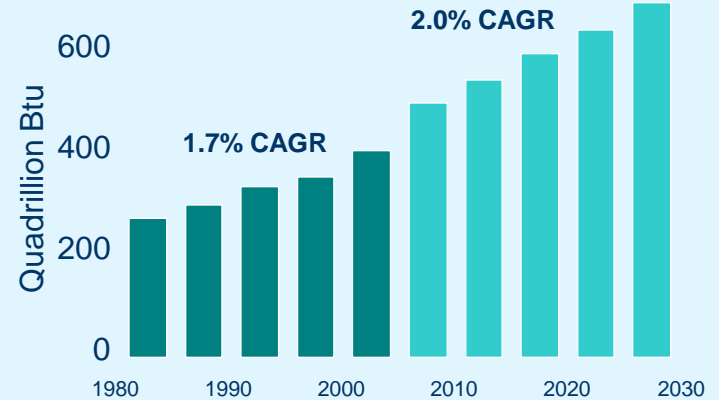

Source: U.S. Department of Energy, IEO2006

Global capital spend (\$bn)

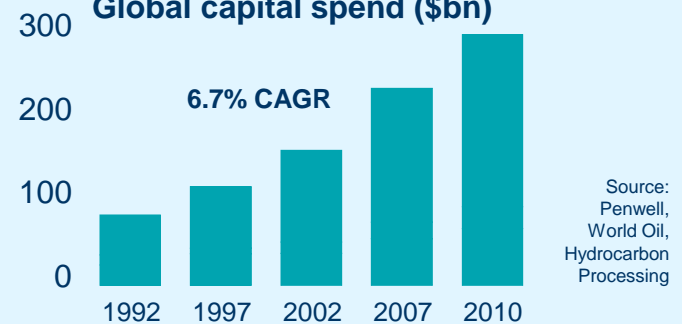

Source: Penwell, World Oil, Hydrocarbon Processing

Market driven by energy consumption – long term growth

Petrochemical route to market

Operating in sectors of high growth

smiths

bringing technology to life

John Crane

Strong customer relationships

End Users



ExxonMobil

ConocoPhillips

HOVENSA

PDVSA



KOCH INDUSTRIES INC



VALERO ENERGY CORPORATION

OEMs



Nuovo Pignone



ITT

TEXTRON

WEHA

SULZER

FLOWSERVE

DRESSER-RAND



Initial End User Specification

End user specifies Smiths' products in new equipment purchase

Petrochemical route to market

Operating in sectors of high growth

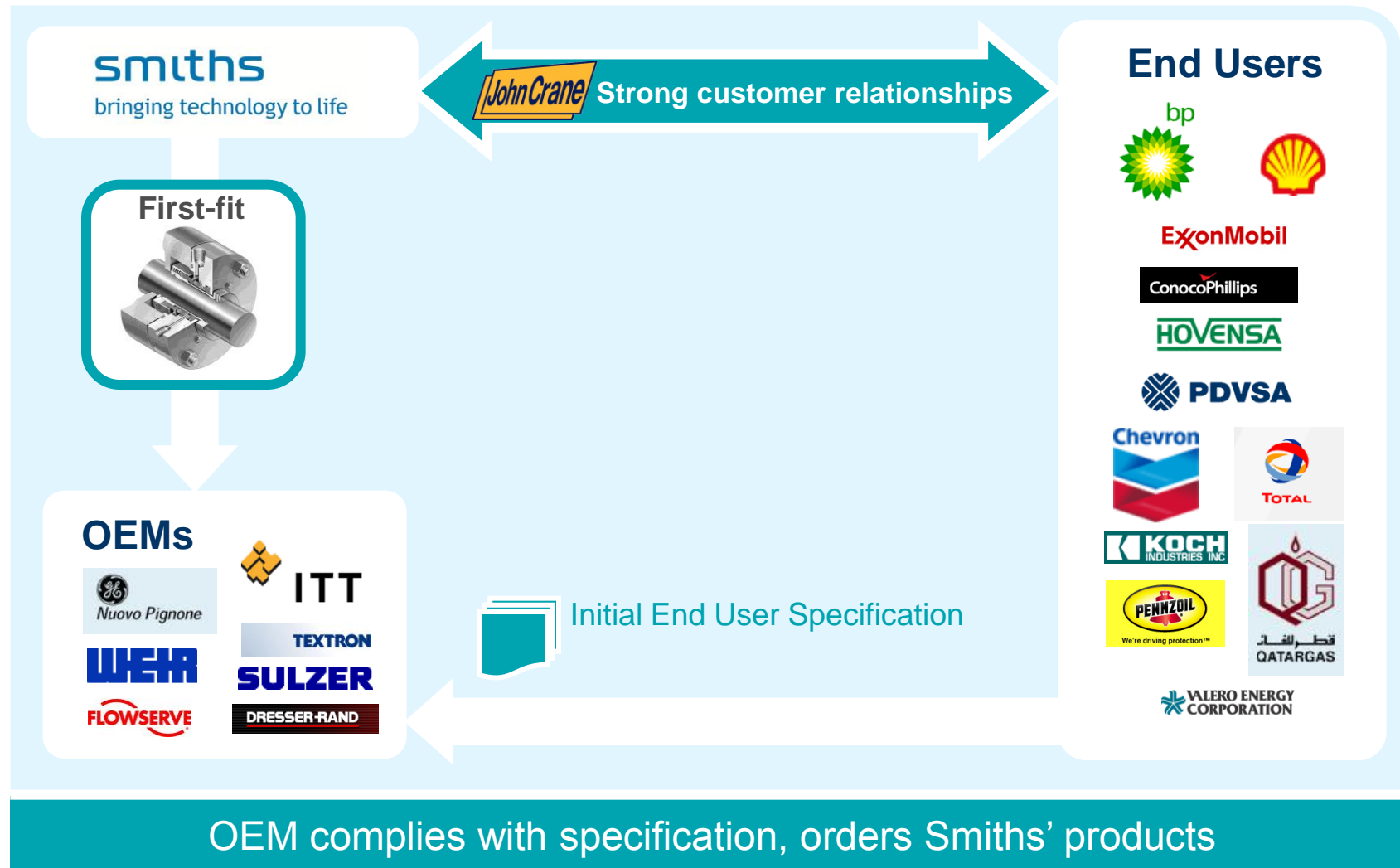

Petrochemical route to market

Operating in sectors of high growth

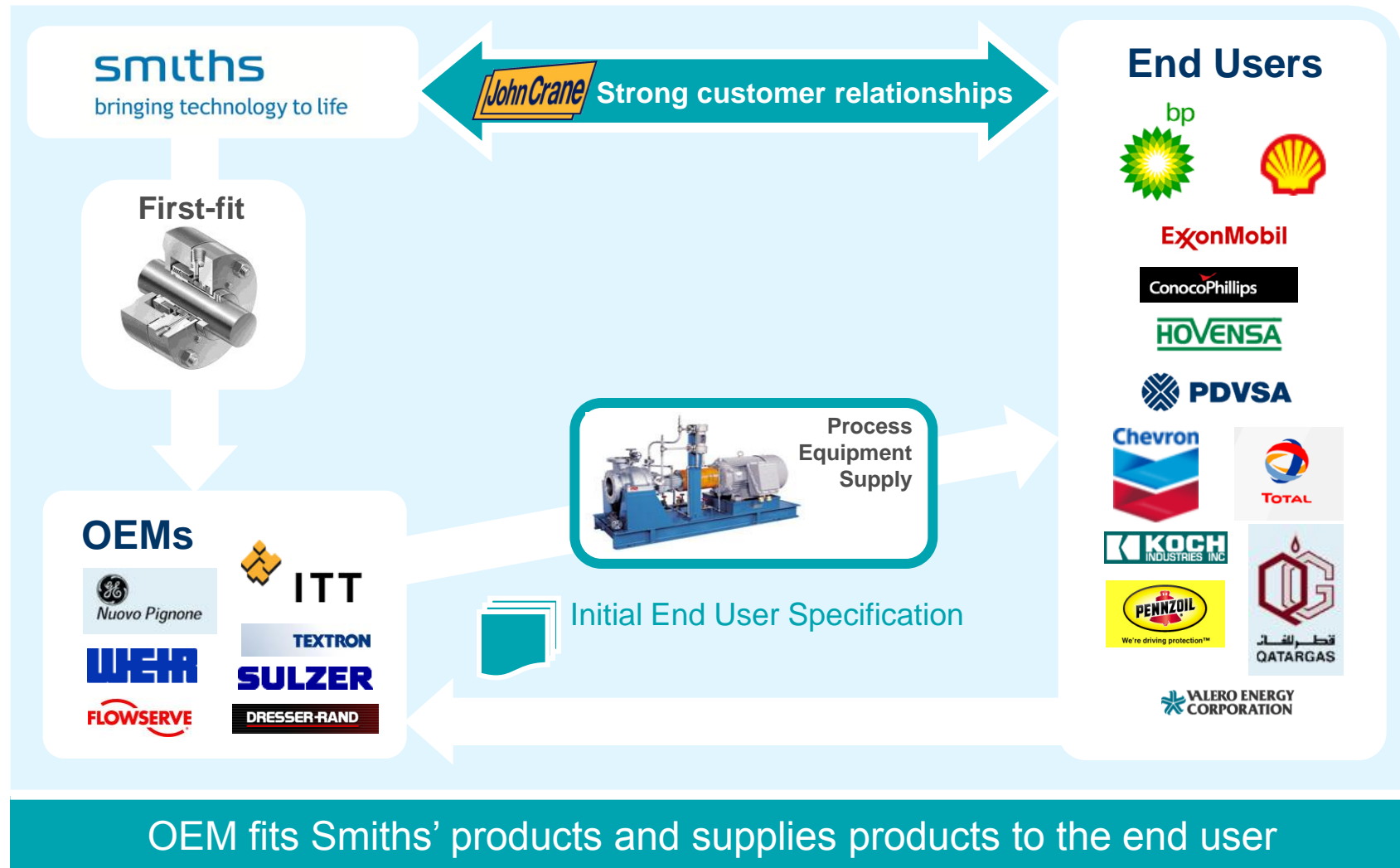

Petrochemical route to market

Operating in sectors of high growth

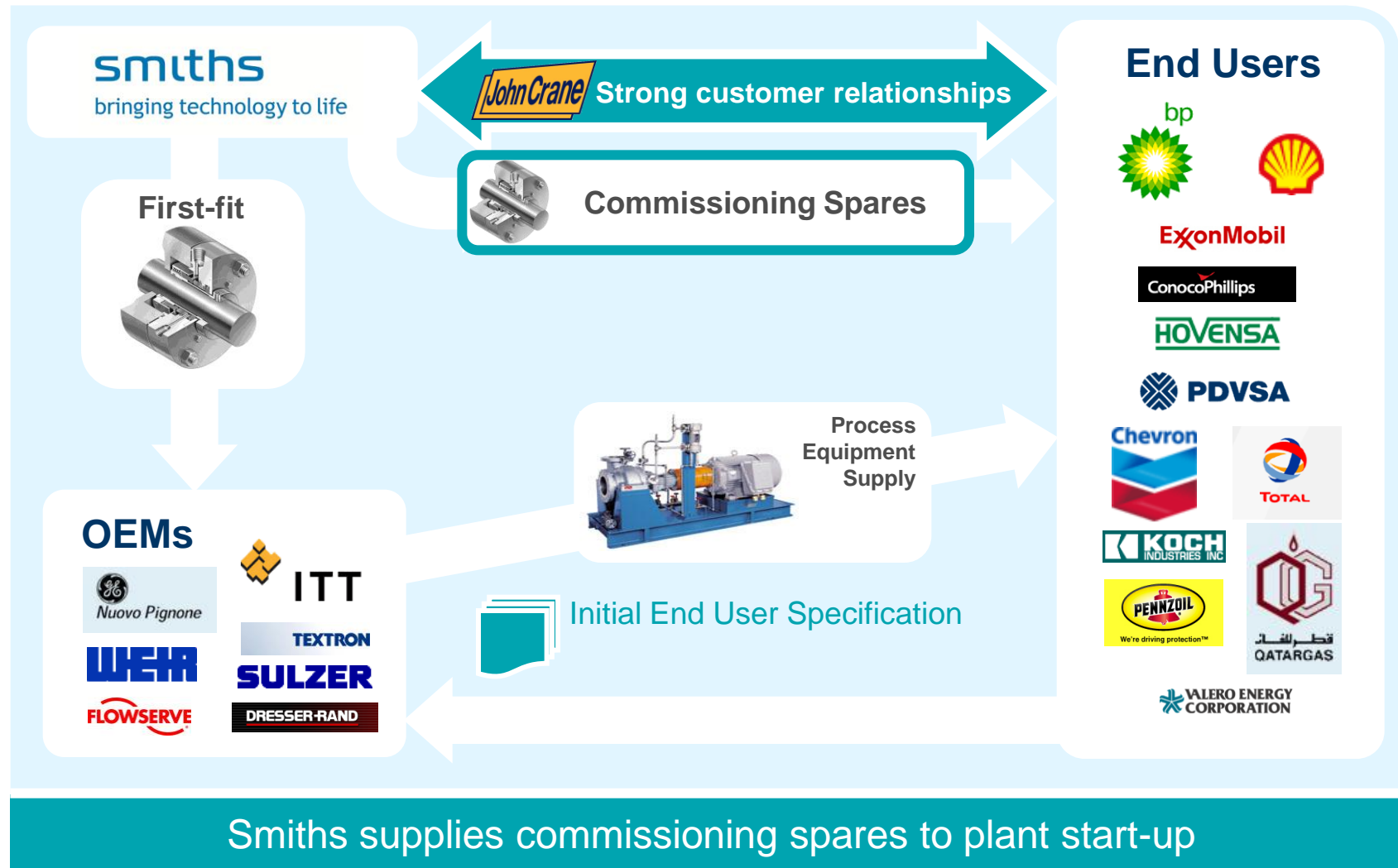

Petrochemical route to market

Operating in sectors of high growth

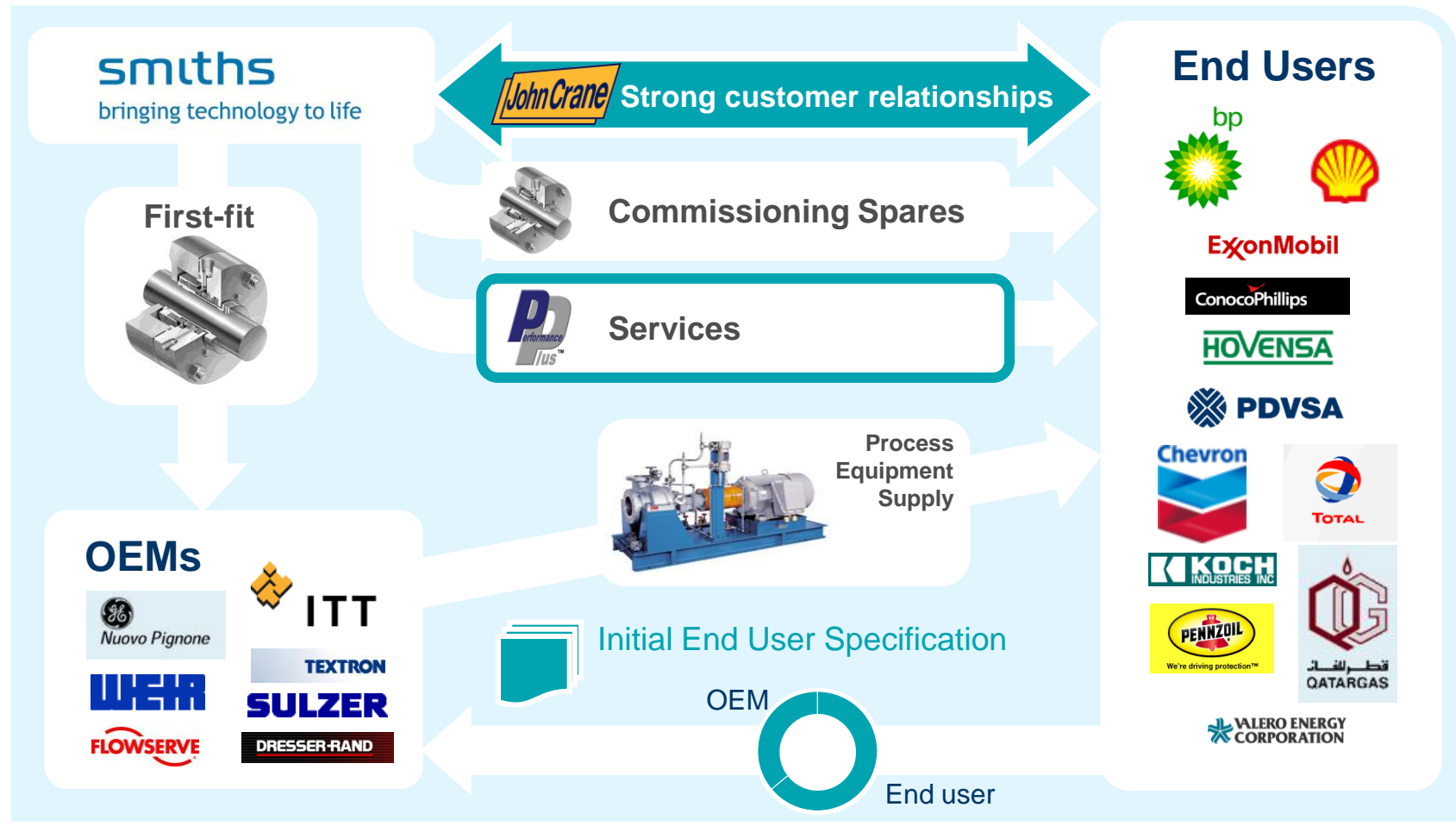

Smiths supplies operating spares and services for life of plant

Specialty Engineering markets

Operating in sectors of high growth

2006 Revenues by market (£1.1bn)

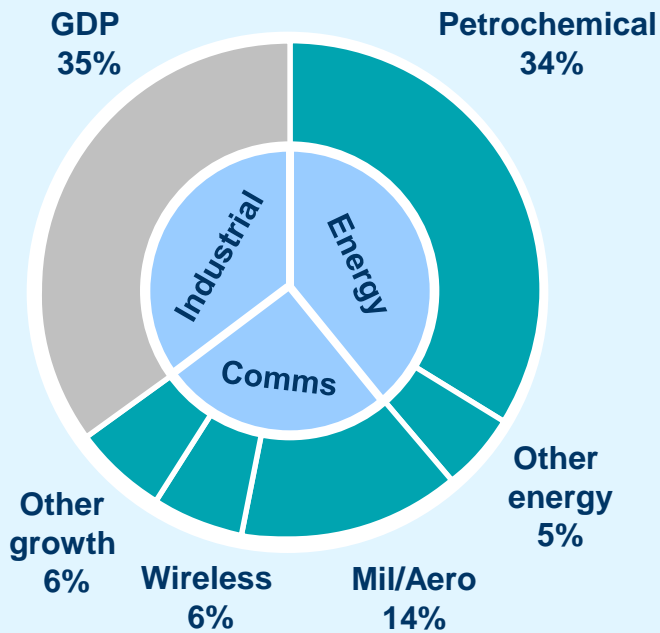

Markets	John Crane	Interconnect	Flex-Tek	Marine
Petrochemical				
Mil/Aero				
Wireless				
Other Energy				
Other Growth				
GDP Markets				

Key: ← % revenues in market

Roughly two thirds of revenues in growth markets

Military/Aerospace market drivers

Operating in sectors
of high growth



Current levels of military spending expected to be sustained

US DoD budget expected to grow

Force modernisation, self protection and network centric warfare are focus areas

High growth sectors include:

- Un-manned Aerial Vehicles
- Next generation ground vehicles
- Communication systems
- Surveillance systems
- Self protection systems

US DoD Procurement Budget (US\$bn)

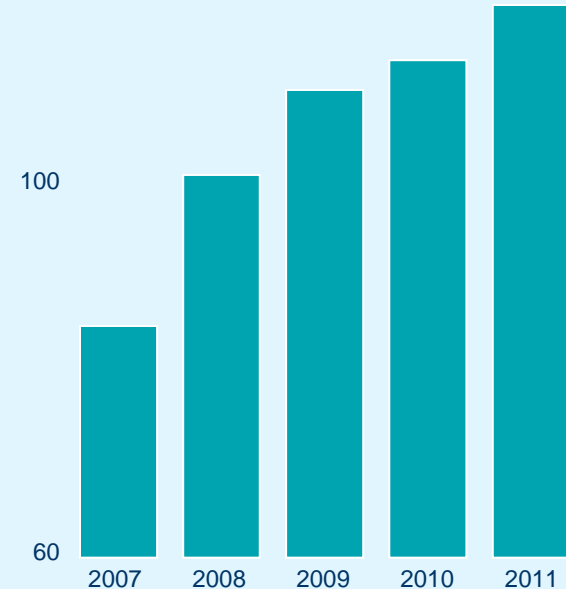

Source: CIBC/Wall Street

In 2007, \$15bn specifically for self protection systems

Positioning on Strategic Growth programmes

Specialty Engineering markets

Operating in sectors of high growth

2006 Revenues by market (£1.1bn)

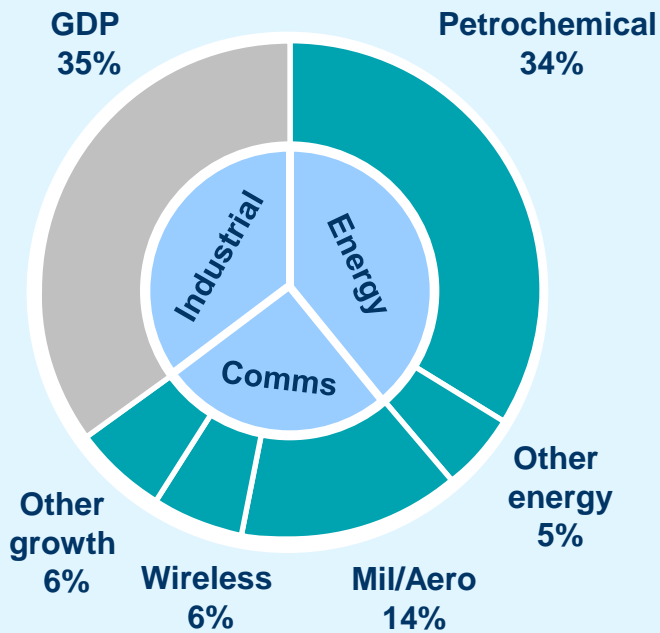

Markets	John Crane	Interconnect	Flex-Tek	Marine
Petrochemical				
Mil/Aero				
Wireless				
Other Energy				
Other Growth				
GDP Markets				

Key: ← % revenues in market

Roughly two thirds of revenues in growth markets

Wireless infrastructure market drivers

Operating in sectors
of high growth



- Worldwide wireless telecommunications growing at 9% pa through 2010
- US wireless subscribers growing solidly (6% pa)
- India and China subscribers growing 16% pa to over 1bn in 2010
- Subscribers demanding
 - greater coverage
 - better connectivity
 - increased functionality
- Driving need for infrastructure spending

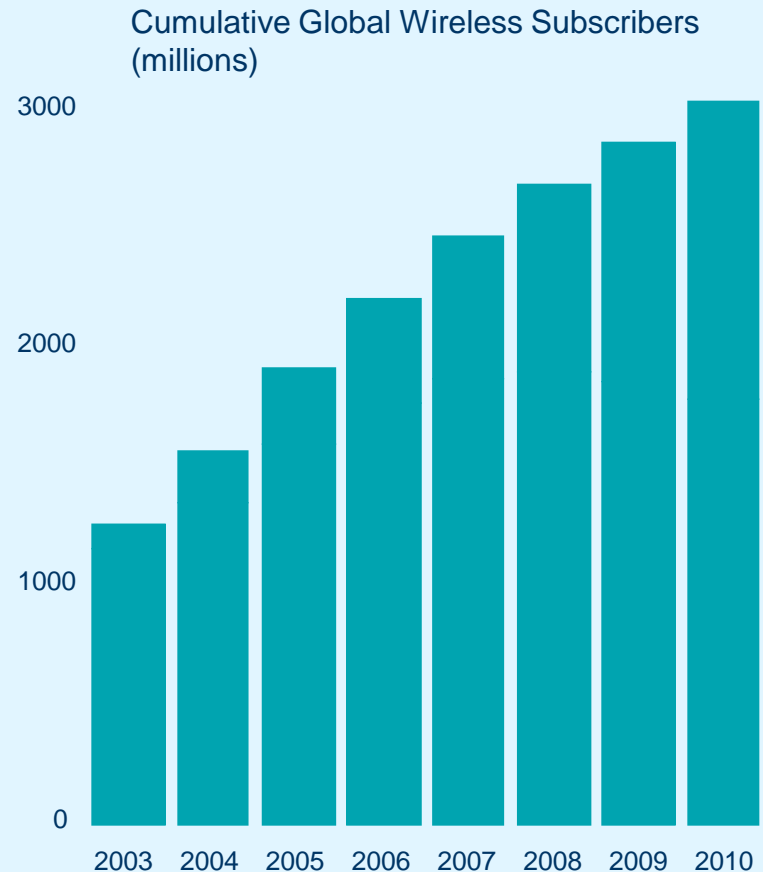

Growth arising from increasing subscribers and data demand

Geographic footprint/customer coverage

Reaching deep
into global markets

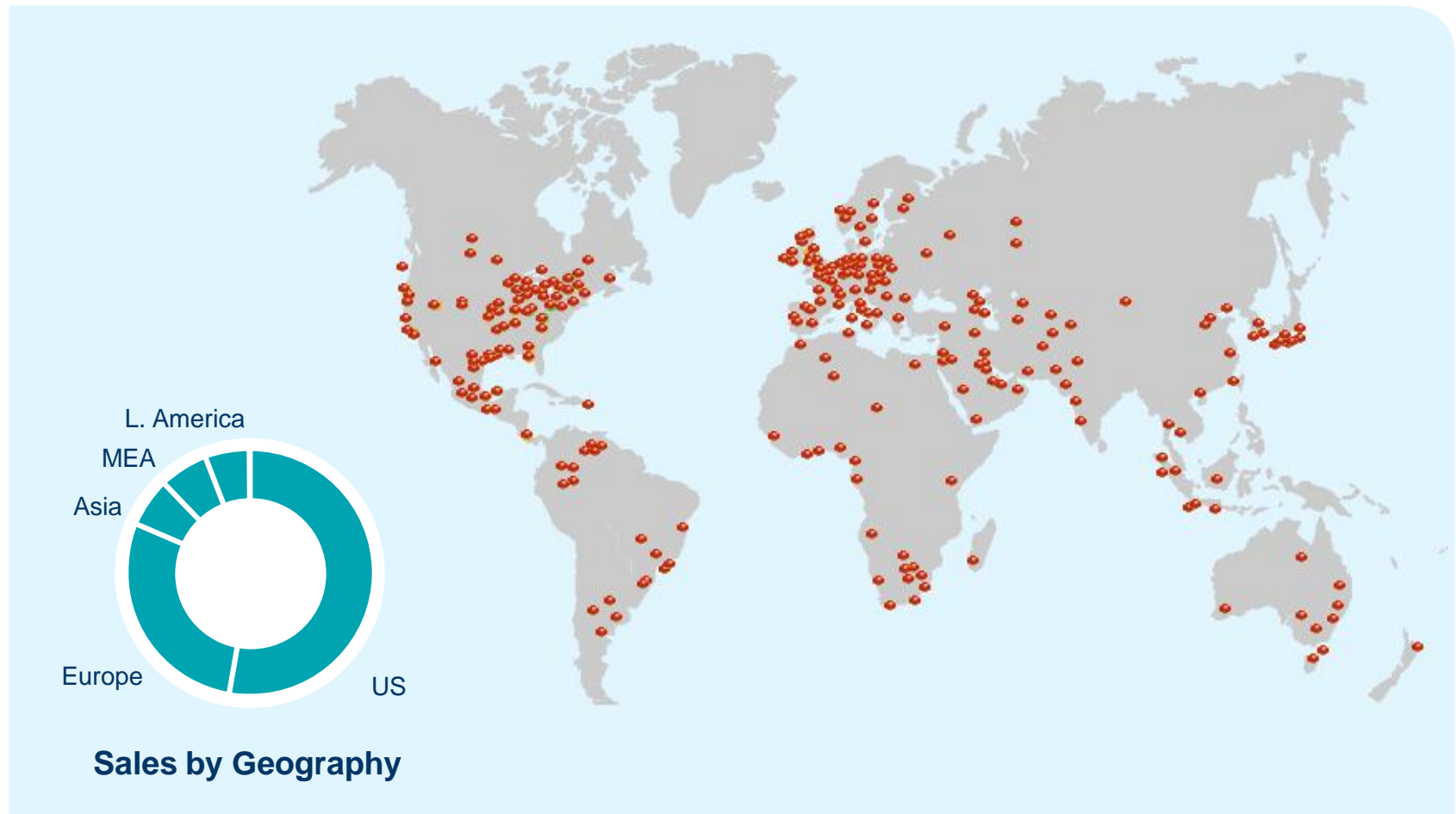

Physical presence in 48 countries, 11,250 employees, of which 2,600 in low cost areas

Bringing technology to life

Developing
technology to help
customers succeed

Strategic Platforms



John Crane Technologies & Services



Interconnect Electronics Technologies



Flex-Tek Engineered Flow/Heat Technologies

- Significant application engineering in cost of sales
- c1,200 engineers worldwide
- 2% R&D spend as percentage of revenue

Efficient innovation engines
to drive future returns

John Crane technologies

Developing technology to help customers succeed

Dry Gas Seal - Spiral grooves provide hydrodynamic lift-off, separating faces on a film of gas.

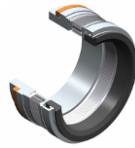

High Temperature and Corrosion Resistant - Thermally compliant, pressure balanced face retention system



Dry-running Seal - Low friction contacting materials/designs



Active noise attenuation of dry-running seal faces



Upstream Pumping – utilising spiral grooves to pump buffer liquid upstream into the process

Oil Plus

Oilfield Chemistry Consultancy – analytical techniques and apparatus



Wireless Condition Monitoring – vibration, temperature, pressure data collection

Specac

Infra-Red sample handling equipment



Gas Control Panel to control, condition and monitor gas barrier

Selective development & acquisition of valued technologies

John Crane technologies - Where our products are used

Developing
technology to help
customers succeed

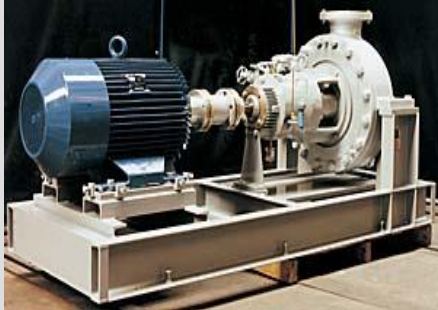

Pumps



Compressors



Wells



Agitators

Wide range of applications

John Crane technologies - Pump application

Developing technology to help customers succeed

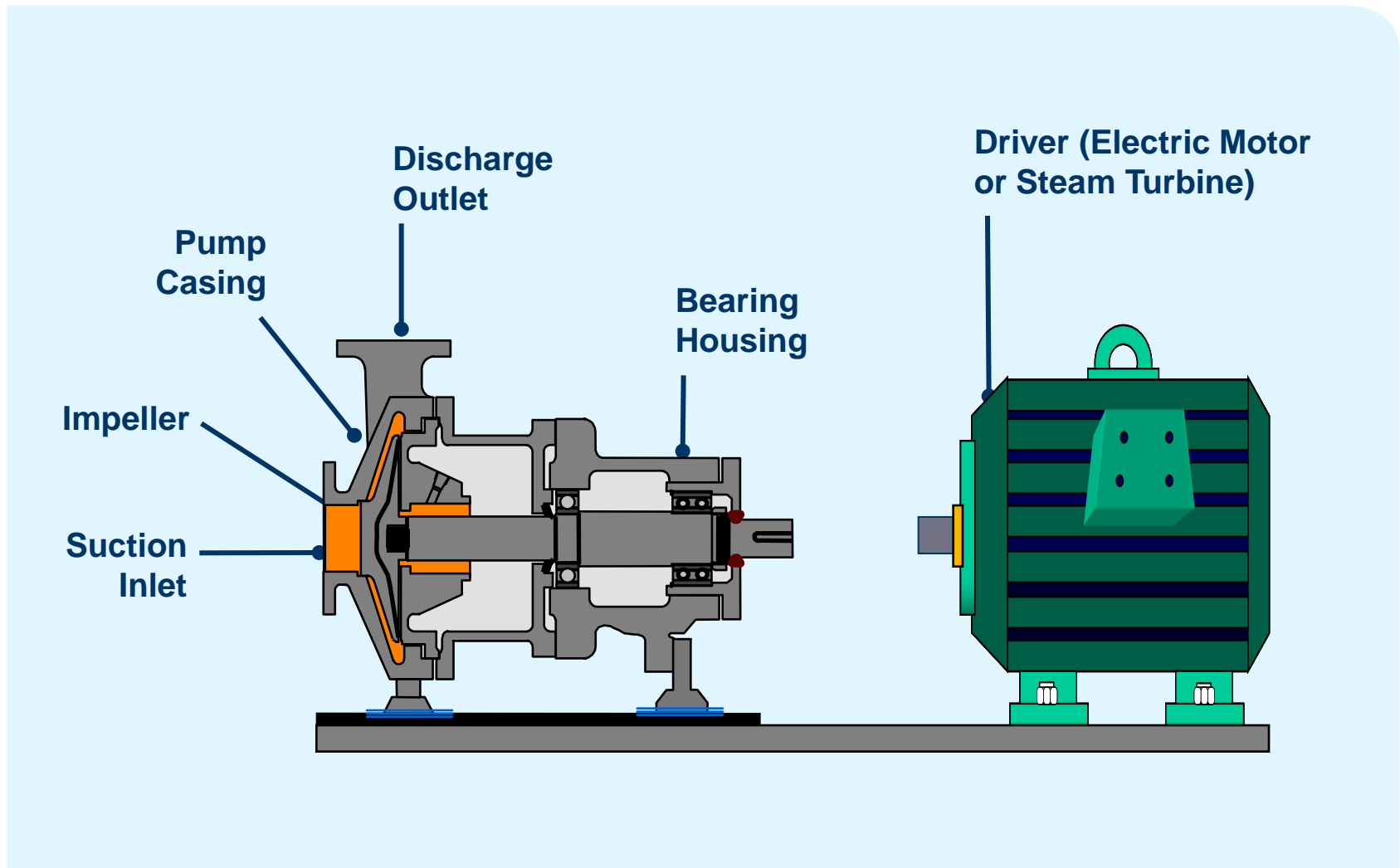

John Crane technologies - Pump application

Developing technology to help customers succeed

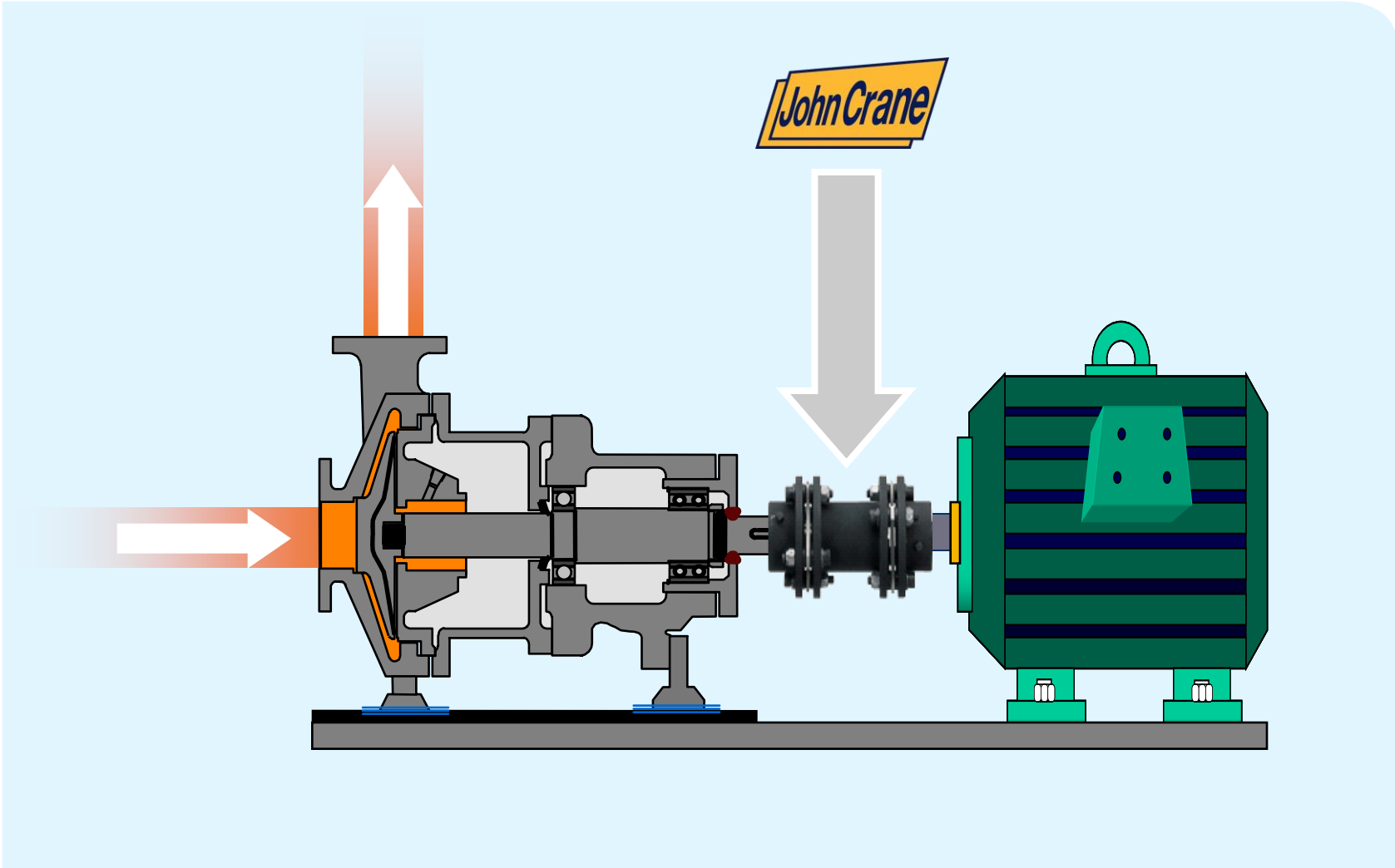

John Crane technologies - Pump application

Developing technology to help customers succeed

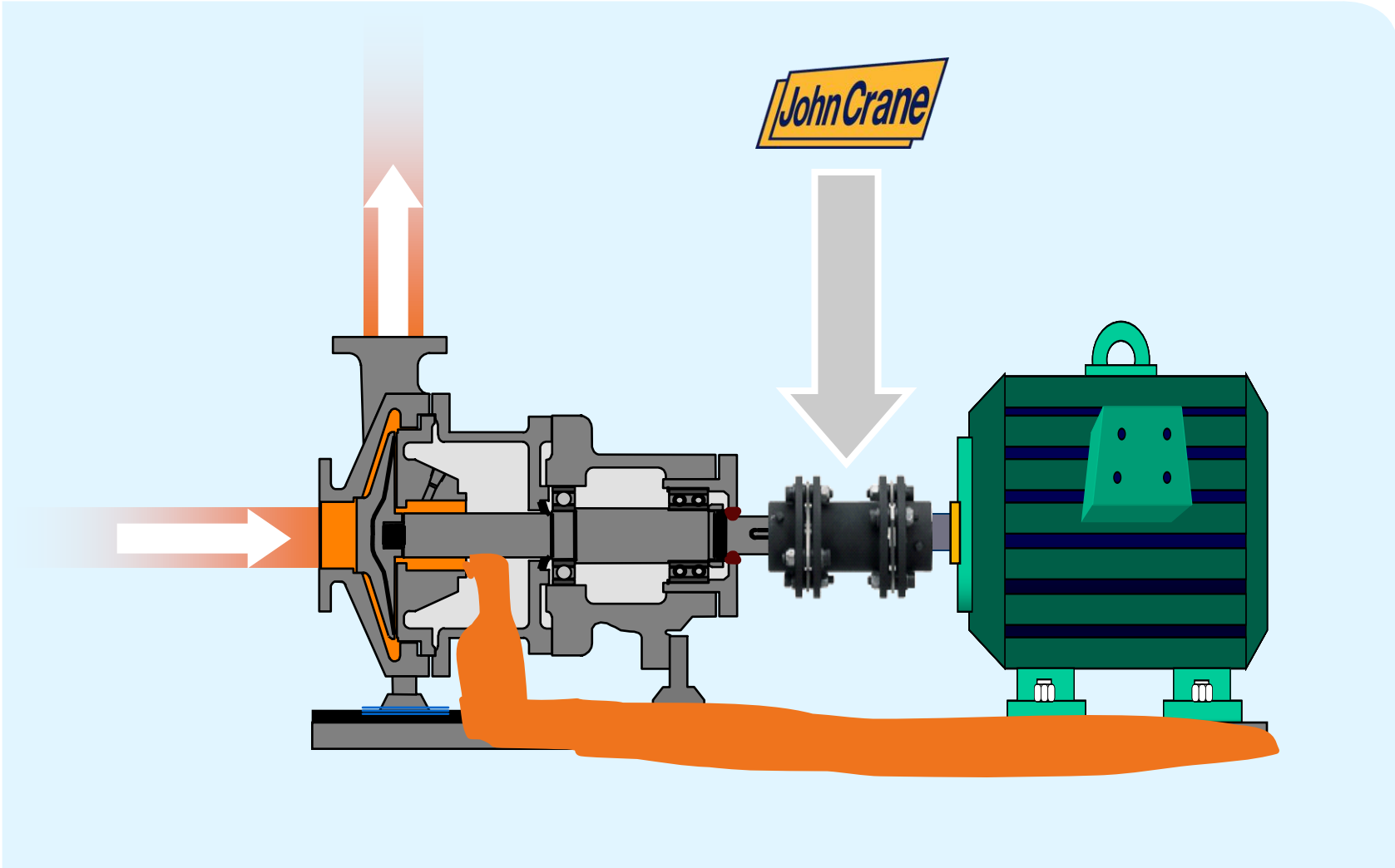

John Crane technologies - Pump application

Developing technology to help customers succeed

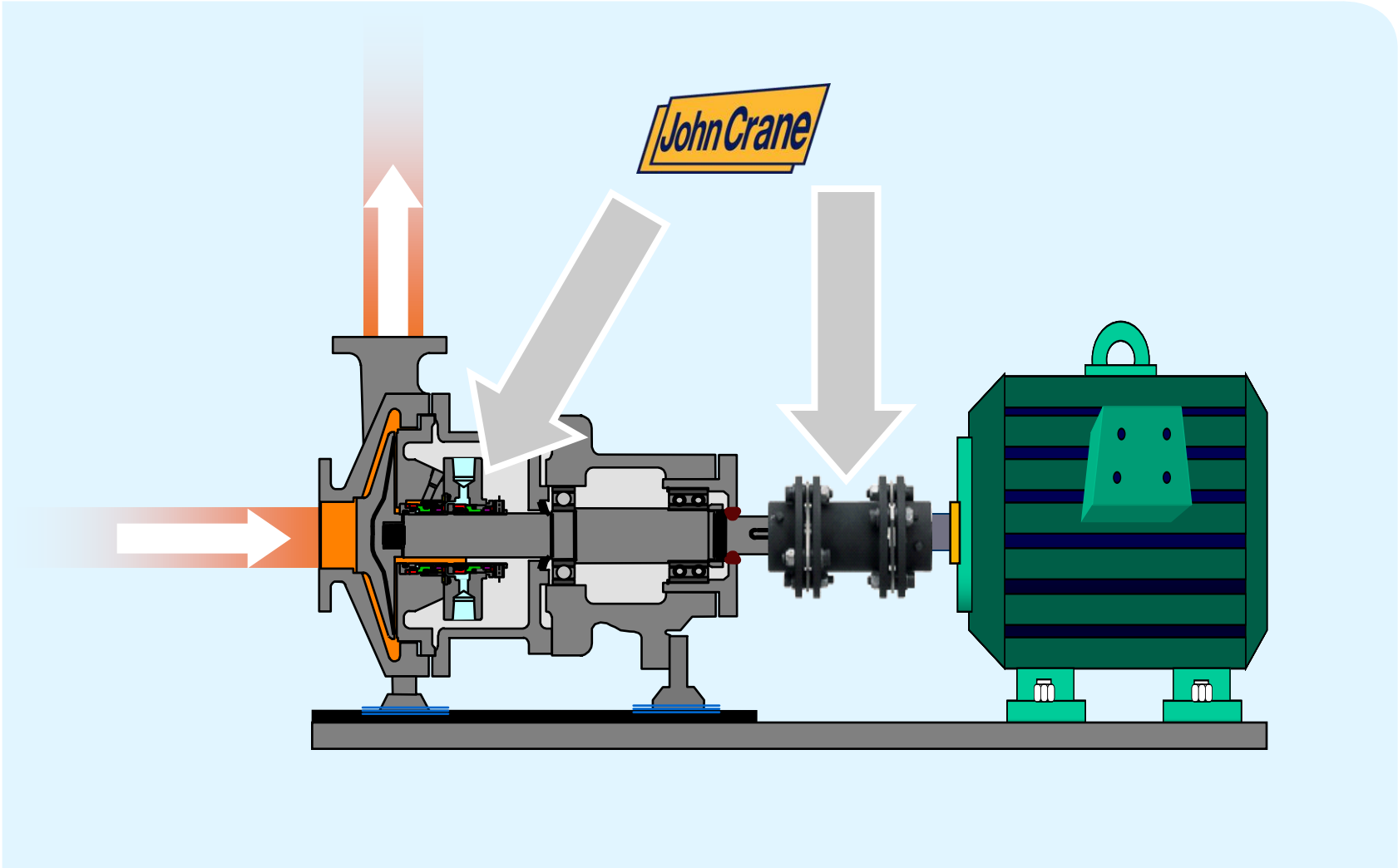

John Crane technologies - Pump application

Developing technology to help customers succeed

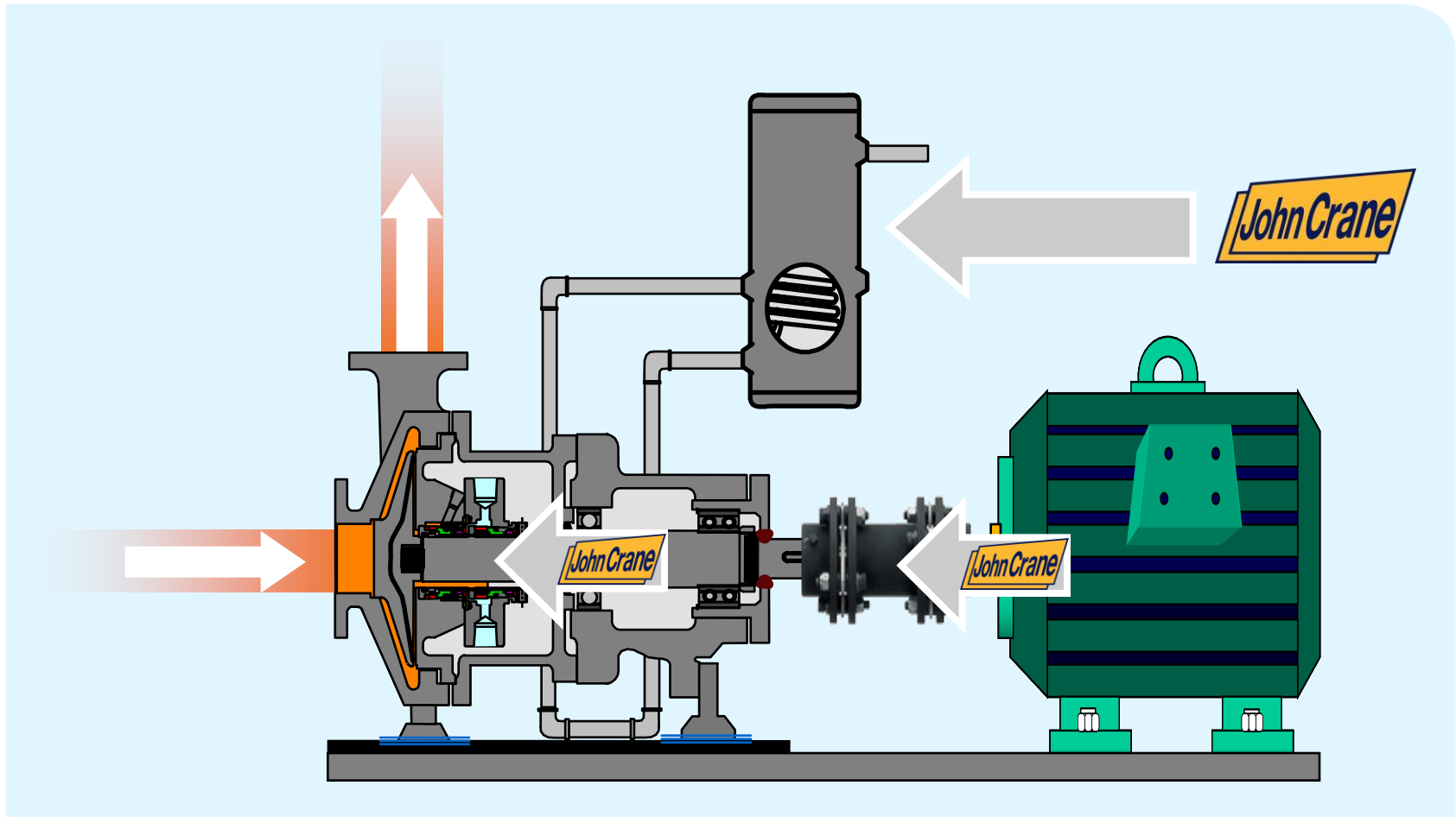

Providing mission critical products to process industries

John Crane technologies - What we do - from crude oil to finished product

Developing
technology to help
customers succeed

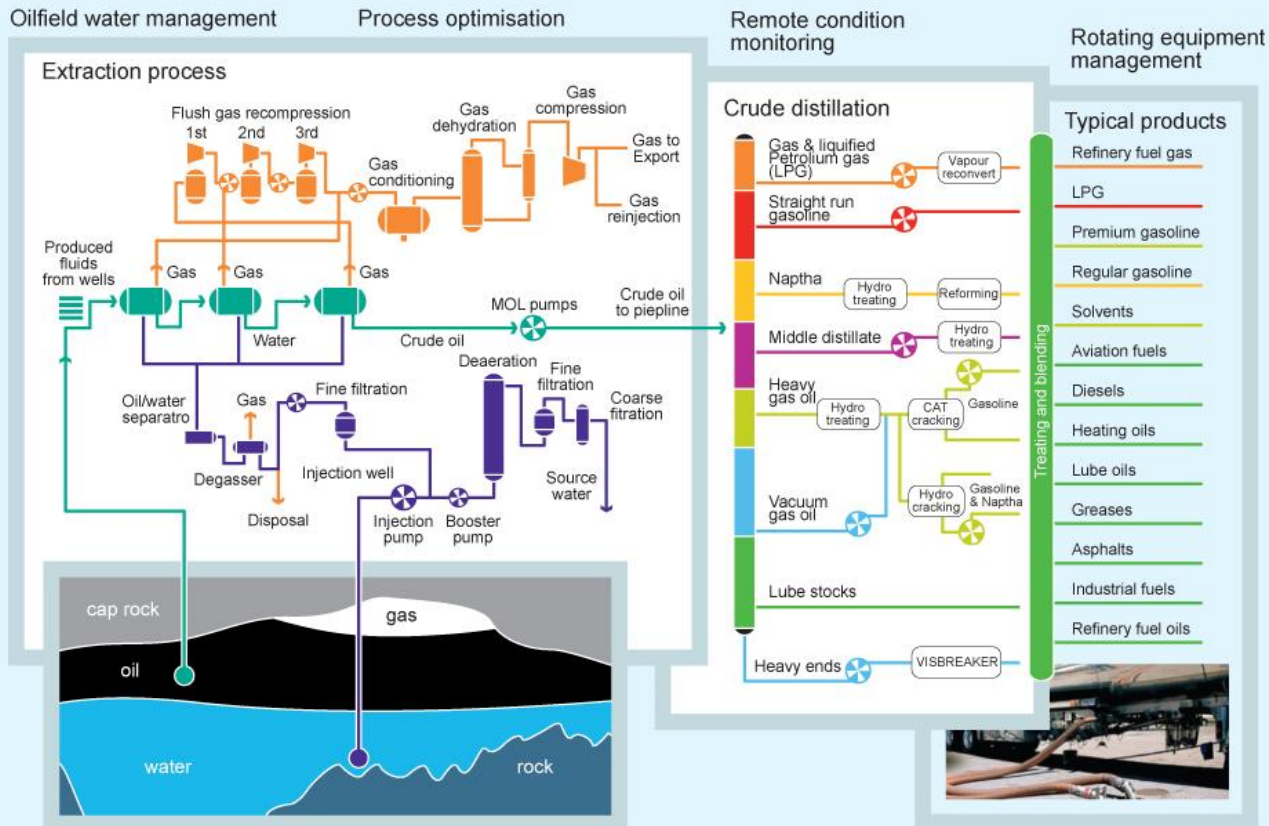

John Crane technologies - What we do - Artificial Lift Rod Pump

Developing
technology to help
customers succeed

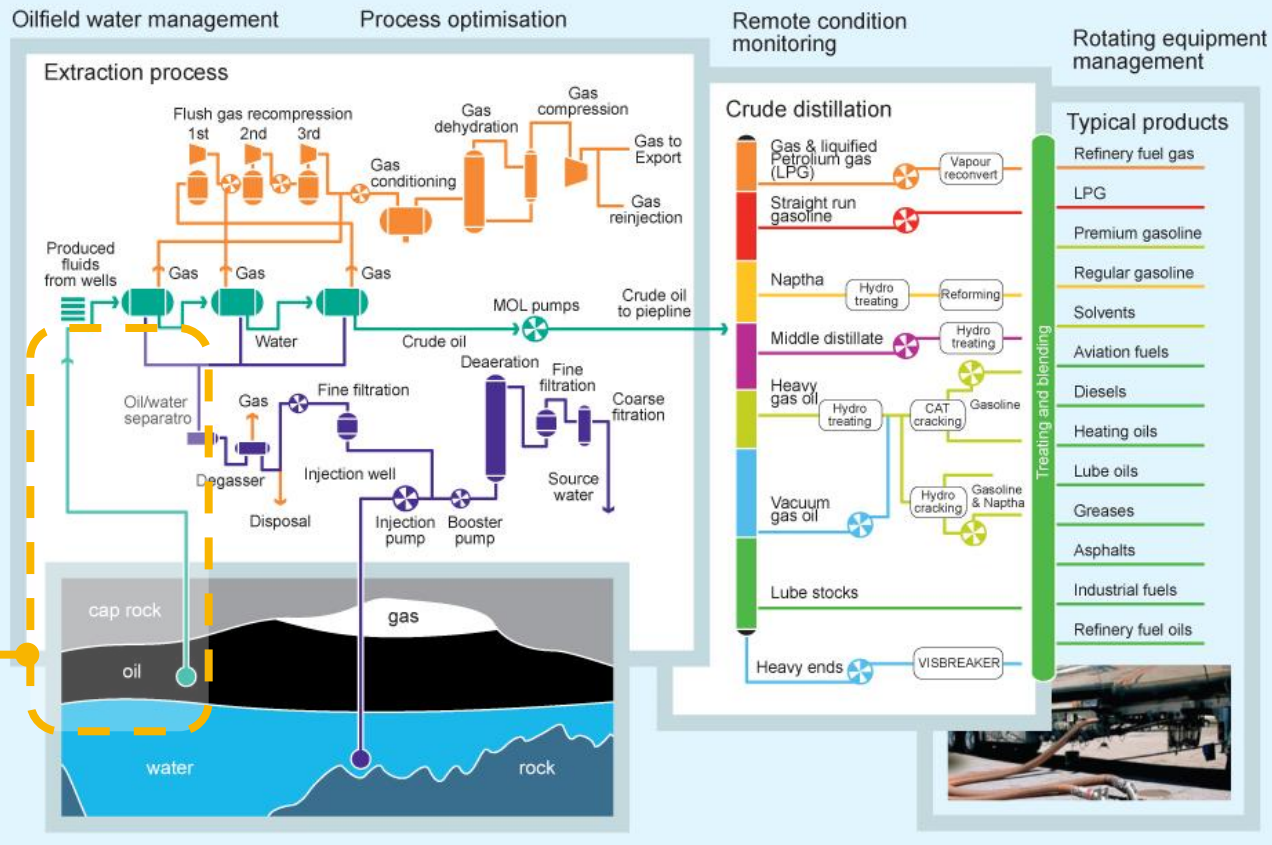

John Crane technologies - What we do - Oil & Water chemistry consultancy

Developing technology to help customers succeed

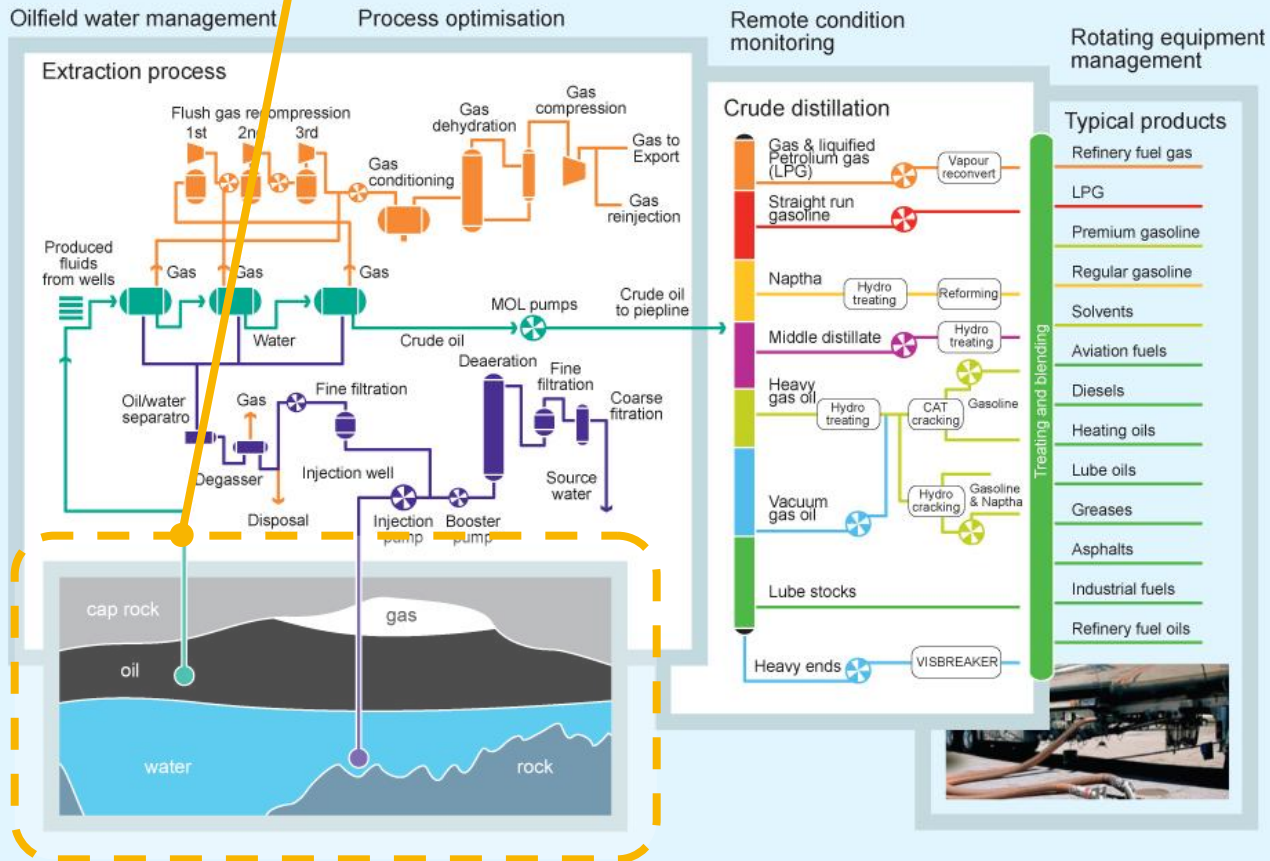

John Crane technologies - What we do - Dry gas seals for turbo compressors

Developing
technology to help
customers succeed

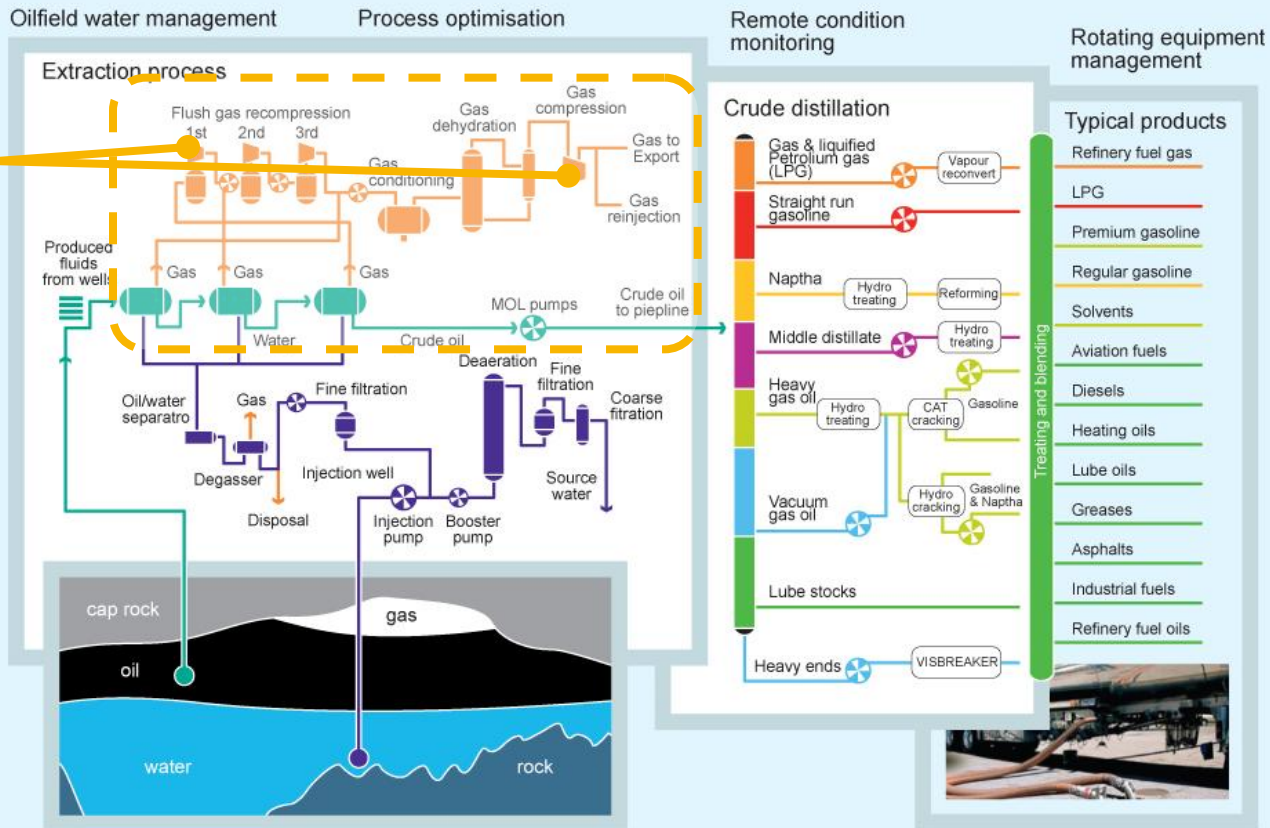
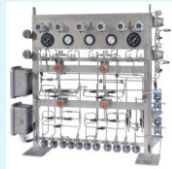

John Crane technologies - What we do - Mechanical seals and couplings for pumps

Developing technology to help customers succeed



Oilfield water management

Process optimisation

Remote condition monitoring

Rotating equipment management

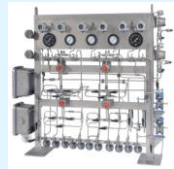

Extraction process

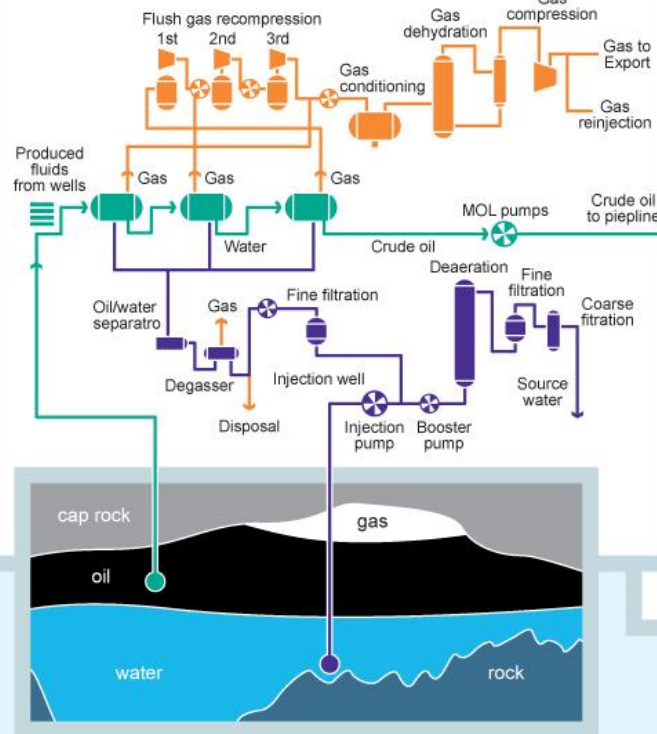

Crude distillation

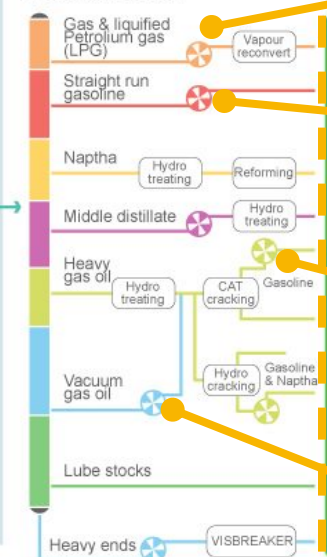

Typical products

- Refinery fuel gas
- LPG
- Premium gasoline
- Regular gasoline
- Solvents
- Aviation fuels
- Diesels
- Heating oils
- Lube oils
- Greases
- Asphalts
- Industrial fuels
- Refinery fuel oils

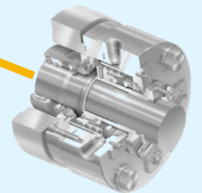
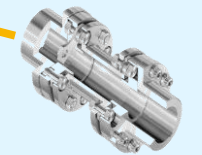
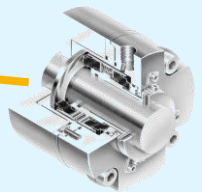
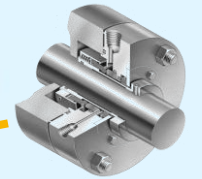

John Crane technologies - What we do - Rotating equipment performance management

Developing technology to help customers succeed

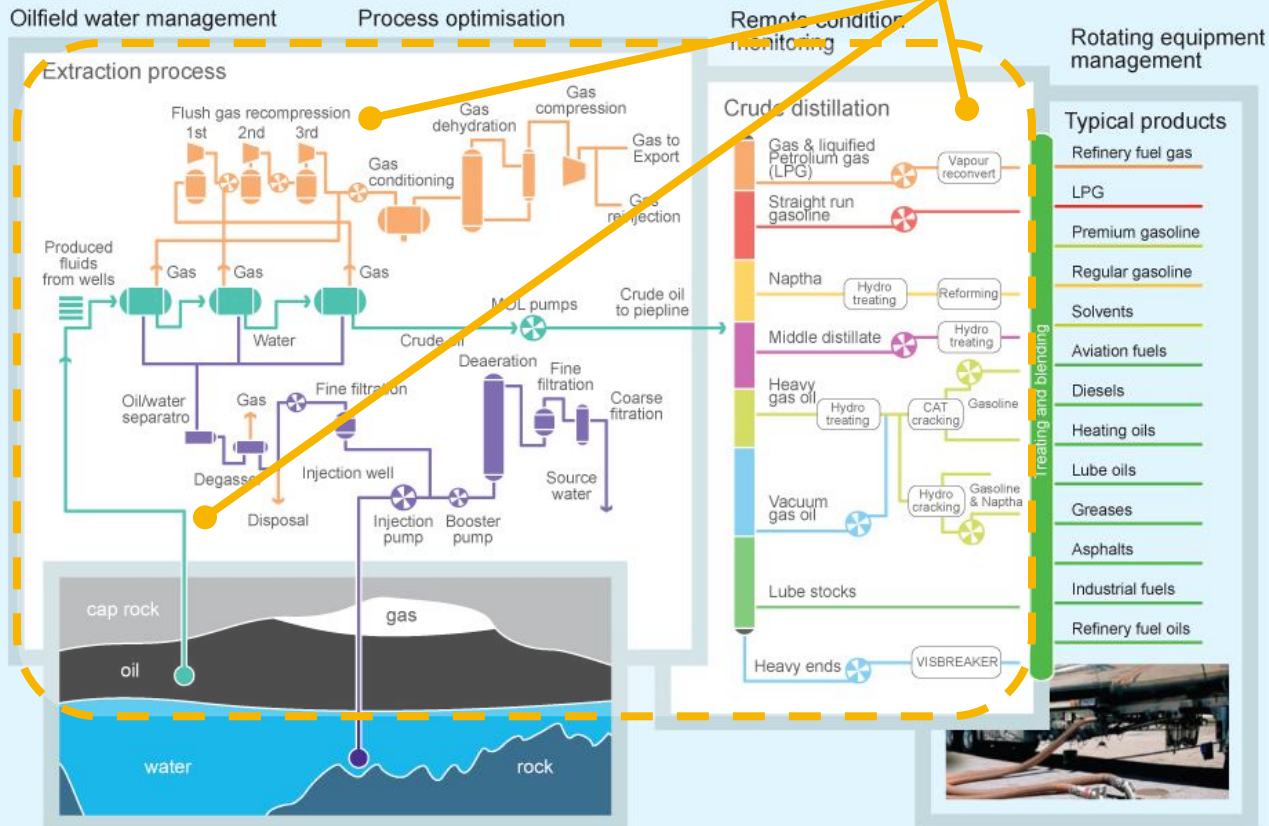
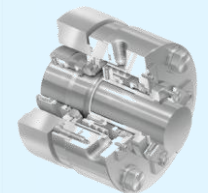
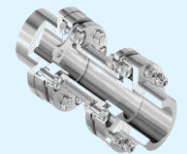
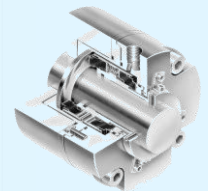
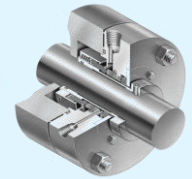
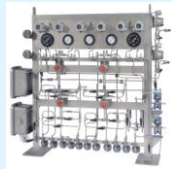
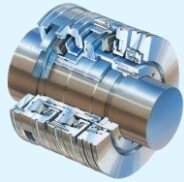

John Crane technologies - What we do - Wireless Condition Monitoring

Developing
technology to help
customers succeed



Oilfield water management

Process optimisation

Remote condition monitoring

Rotating equipment management

Extraction process

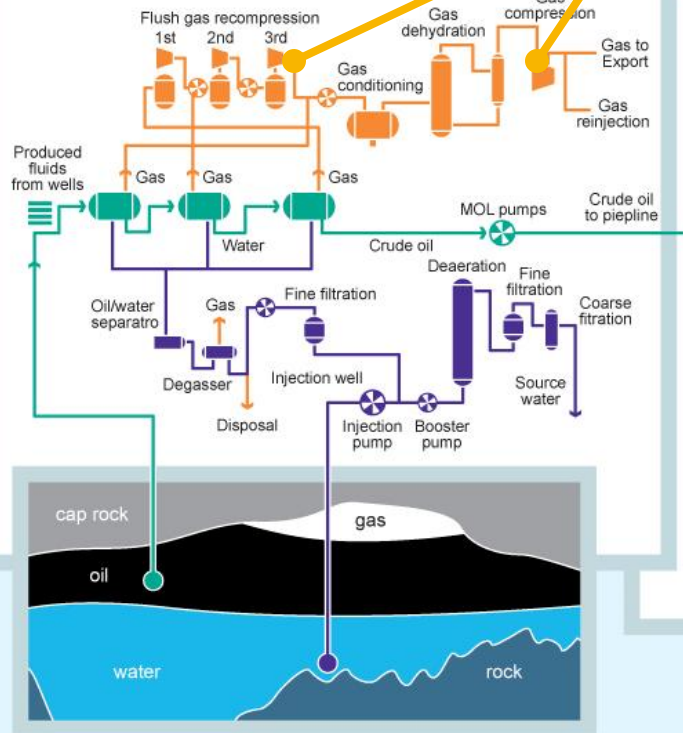

Crude distillation

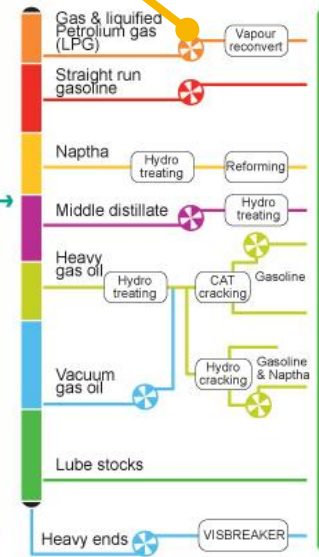

Typical products

- Refinery fuel gas
- LPG
- Premium gasoline
- Regular gasoline
- Solvents
- Aviation fuels
- Diesels
- Heating oils
- Lube oils
- Greases
- Asphalts
- Industrial fuels
- Refinery fuel oils

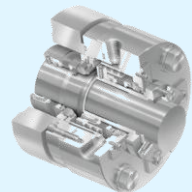
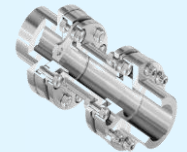
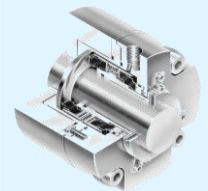
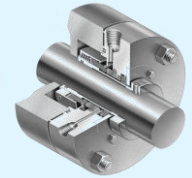
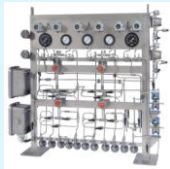
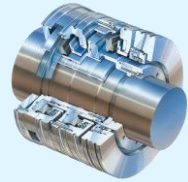

End to End Mission Critical Products & Services

Interconnect electronics technologies

Developing
technology to help
customers succeed

Microwave



Components and sub-systems used in the generation, transmission, receipt and processing of high frequency signals

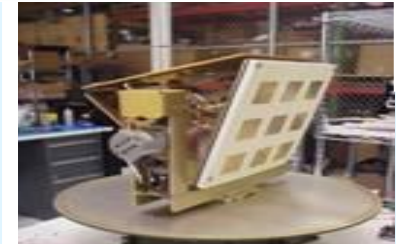

Connectors



Application specific high reliability electrical interconnect solutions



Protection



Components used to protect high value electrical systems from surges caused by power spikes and lightning strike



Selective development & acquisition of valued technologies

Interconnect electronics technologies - Microwave system application

Developing
technology to help
customers succeed

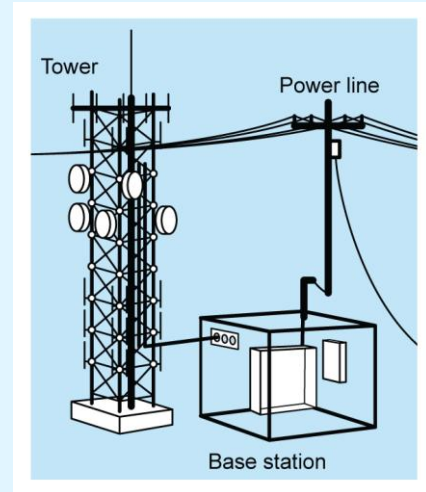
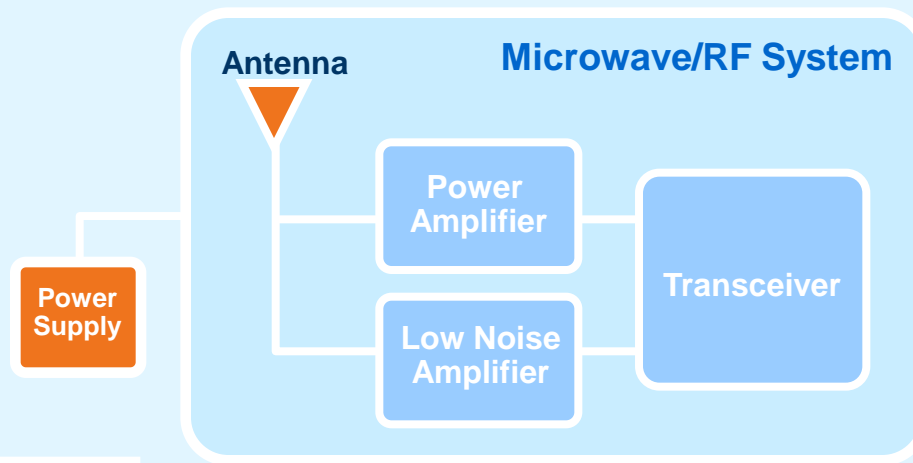

**Communications
systems**



**Sensor
systems**

Interconnect electronics technologies - Where our products are used

Developing
technology to help
customers succeed

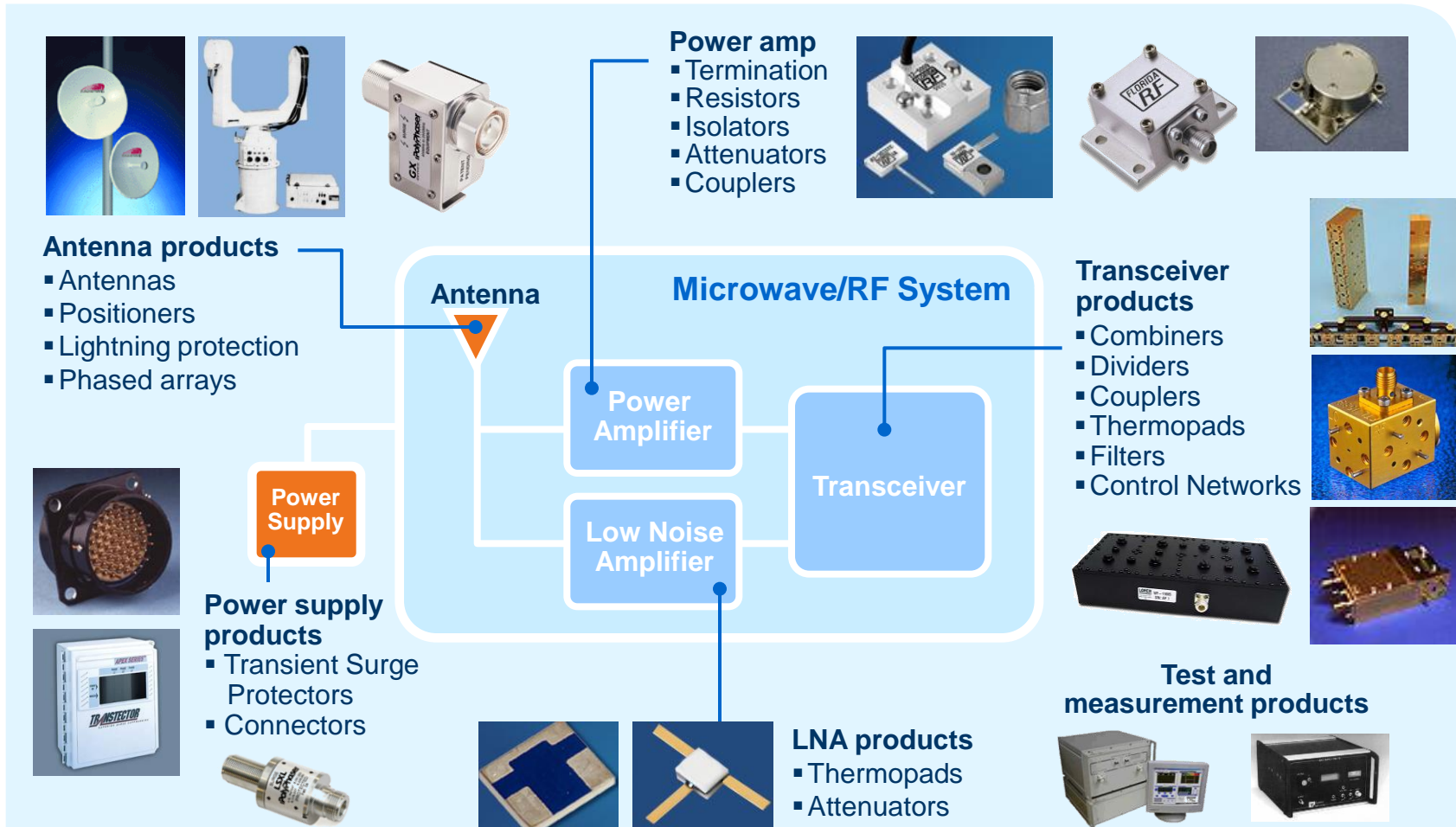

Niche components and sub-systems with broad applications

Interconnect electronics technologies - What we do - Network centric warfare

Developing
technology to help
customers succeed

Mobile Directional Antenna System (MDAS) for US Army

- Tactical Data Link for Unmanned Aerial Vehicles (UAVs)
- Supports multiple UAV Types
- MDAS Provides situational awareness to troops

Differentiators:

- First antenna to integrate multiple UAV frequencies into single units and be mobile
- Prototype developed in less than 6 months. High rate production in just 60 days from 1st prototype delivery
- Selected based on customer relationship and past performance

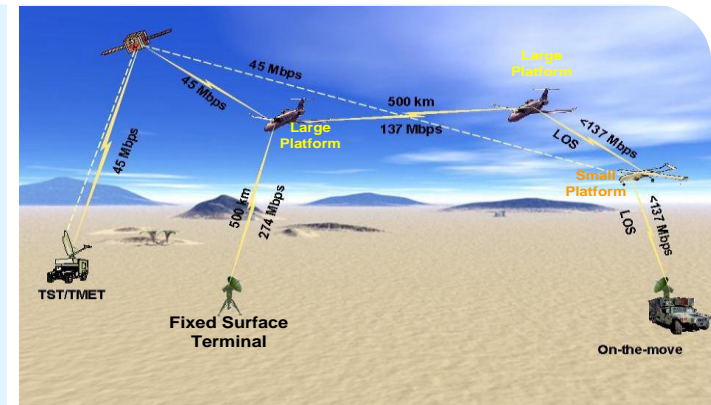

Right Technology + Excellent Execution = WIN

FlexTek - Engineered flow/heat technology

Developing
technology to help
customers succeed

Engineered Flow

- Proprietary hose and tubing technology
- Total system provider for natural gas delivery
- Patented fitting design and leader in code development
- Precision fluoropolymer extrusion and braiding
- Complex rigid tubing assemblies in high ferrous metals

Heat Technology

- Open coil convection heating
- Complete thermal systems for precise control of air and gas temperature

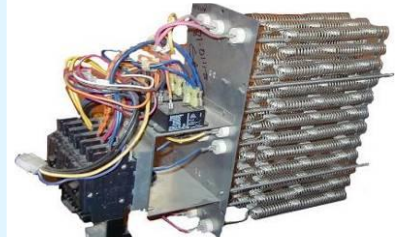
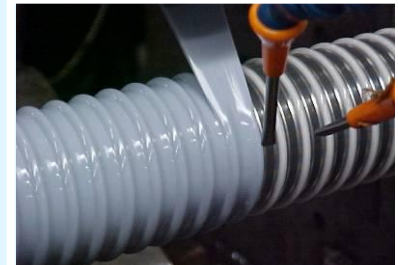

Innovators of heating & moving fluids / gases

FlexTek - Engineered flow / heat applications and markets

Developing
technology to help
customers succeed

Engineered Flow

- **Appliances** - Leading global provider of specialist hoses for the treatment of sleep apnea and floor care equipment
- **Aerospace** - Global manufacturer of rigid and flexible engineered fluid distribution solutions for aerospace applications
- **Construction** - US market leader in flexible stainless steel natural gas delivery tubing and leader in high-end HVAC ducting

Heat Technology

- **Appliances** - Largest manufacturer of heating elements for clothes tumble dryers and HVAC equipment in North America
- **Other** - Extensive applications range: medical, semi-conductor, bio-fuels, laboratory equipment



Design & Manufacturing Innovation key to success

Specialty Engineering - Constant improvement

Delivering constant
improvement

Improving
the business mix

- Product development
- Lean focus
- Strategic sourcing
- Systems & processes
- Proactive M&A

Specialty Engineering margins

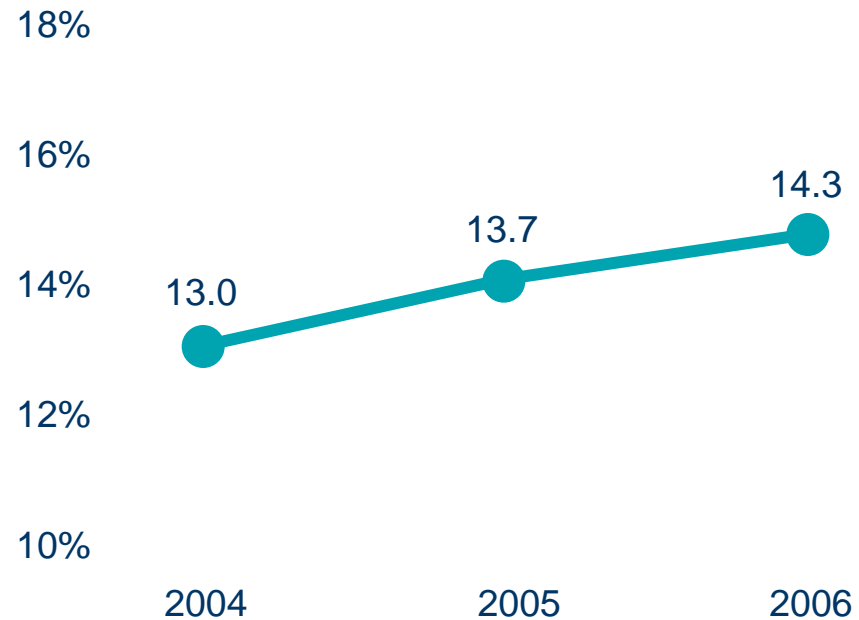

Sustainable margin improvements

Specialty Engineering Summary



Attractive growth markets



Strong customer relationships



Excellent technologies



Margin improvements



Aftermarket opportunities



Bolt on acquisitions

Well positioned for sustainable growth